

ISOMETER® isoHV425xx with coupling device AGH422

Insulation monitoring device for unearthed AC, AC/DC and DC systems (IT system) up to 3(N)AC, AC 1000 V, DC 1000 V



ISOMETER® isoHV425xx with coupling device AGH422

Insulation monitoring device for
unearthed AC, AC/DC and DC systems (IT system)
up to 3(N)AC, AC 1000 V, DC 1000 V



ISOMETER® isoHV425xx
with coupling device AGH422

Device features

- Monitoring the insulation resistance for unearthed AC/DC systems
- Measurement of the system voltage (true r.m.s.) with undervoltage and overvoltage detection
- Measurement of DC system voltages to earth (L1+/PE and L2-/PE)
- Automatic adaptation to the system leakage capacitance up to 150 µF
- Selectable start-up delay, response delay and delay on release
- Two separately adjustable response value ranges of 10...500 kΩ (Alarm 1, Alarm 2)
- Alarm signalling via LEDs (AL1, AL2), a display and alarm relays (K1, K2)
- Automatic device self test with connection monitoring
- Selectable N/C or N/O relay operation
- Measured value indication via a multi-functional LC display
- Fault memory can be activated
- Password protection to prevent unauthorised parameter changes

isoHV425-D4-4

- RS-485 (galvanically separated) including the following protocols:
 - BMS interface (Bender measuring device interface) for data exchange with other Bender components
 - Modbus RTU
 - IsoData (for continuous data output)

isoHV425-D4M-4

- 0(4)...20 mA, 0...400 µA, 0...10 V analogue output (galvanically separated)

Certifications



Product description

The ISOMETER® monitors the insulation resistance of unearthed AC, AC/DC and DC systems (IT systems) with nominal system voltages of 3(N)AC, AC/DC 0...1000 V or DC 0...1000 V. The maximum permissible system leakage capacitance C_e is 150 µF. DC components existing in AC systems do not influence the operating characteristics, when a minimum load current of DC 100 mA flows. A separate supply voltage allows de-energised systems to be monitored too.

In order to meet the requirements of applicable standards, customised parameter settings must be made on the equipment in order to adapt it to local equipment and operating conditions. Please heed the limits of the area of application indicated in the technical specifications. Any use other than that described in this manual is regarded as improper.

Application

- AC main circuits up to 1000 V
- DC main circuits up to 1000 V
- Systems including switched-mode power supplies

Variants

- isoHV425-D4-4 with a serial interface
- isoHV425-D4M-4 with an analogue output

Function

The ISOMETER® measures the insulation resistance R_F and the system leakage capacitance C_e between the system to be monitored (L1/+, L2/-) and earth (PE). The RMS value of the nominal system voltage U_n between L1/+ and L2/-, as well as the residual voltages U_{L1e} (between L1/+ and earth) and U_{L2e} (between L2/- and earth) are also measured.

From a minimum nominal system voltage, the ISOMETER® determines the faulty conductor L1/+ or L2/-, i.e. the distribution of the insulation resistance between the conductors L1/+ and L2/-, and indicates this by means of a positive or negative sign preceding the insulation resistance measurement. The value range of the faulty conductor is $\pm 100\%$:

Display	Meaning
-100 %	One-sided fault at conductor L2/-
0 %	Symmetrical fault
+100 %	One-sided fault at conductor L1/+

The partial resistances can be calculated from the total insulation resistance R_F and the faulty conductor (R %) using the following formula:

$$\text{Fault at conductor L1/+} \rightarrow R_{L1F} = (200\% * R_F) / (100\% + R\%)$$

$$\text{Fault at conductor L2/-} \rightarrow R_{L2F} = (200\% * R_F) / (100\% - R\%)$$

It is possible to assign the detected fault or the faulty conductor to an alarm relay via the menu. If the values R_F or U_n violate the response values activated in the "AL" menu, this will be indicated by the LEDs and relays K1 and K2 according to the signalling assignment set in the "out" menu. In addition, the operation of the relay (n.c./n.o.) can be set and the fault memory "M" can be activated.

If the values R_F or U_n do not violate their release value (response value plus hysteresis) for the period t_{off} without interruption, the alarm relays will switch back to their initial position and the alarm LEDs AL1/AL2 go out. If the fault memory is activated, the alarm relays remain in the alarm condition and the LEDs light until the reset button "R" is pressed or the supply voltage U_s is interrupted.

The device function can be tested using the test button "T". Parameters are assigned to the device via the LCD and the control buttons on the front panel; this function can be password-protected. Parameterisation of the isoHV425-D4-4 is also possible via the BMS bus, for example by using a BMS Ethernet gateway (COM460IP) or Modbus RTU.

Connection monitoring

The connections to the electrical system (L1/+ / L2/-) and earth (E/KE) as well as the connecting wires from the ISOMETER® to the coupling device are periodically monitored every 24 hours after pressing the test button and connecting the supply voltage. In case of line interruption, the alarm relay K2 switches, the LEDs ON/AL1/AL2 flash and a message appears on the LC display:

“E.0x” for a fault in the connecting wires between both devices or a system error

“E.02” for a fault in the connecting wires to the system

“E.01” for a fault in the connecting wires to PE

After eliminating the fault, the alarm relays switch back automatically or by pressing the reset button.

Measurement method

The ISOMETER® isoHV425 uses the AMP and PCP measurement method.

Standards

The ISOMETER® isoHV425 series meets the following device standards:

- DIN EN 61557-8 (VDE 0413-8):2015-12/Ber1:2016-12
- DIN EN 50155: 2018-05
- EN 45545-2:2016
- IEC 61557-8:2014/COR1:2016

Ordering information

Supply voltage U_s		Nominal voltage U_n	Version	Type	Art. No.
AC	DC	AC, 3(N)AC, DC			
100...240 V, 47...63 Hz	24...240 V	0...1000 V	Serial interface	isoHV425-D4-4 with AGH422	B71036501
				isoHV425W-D4-4 with AGH422W	B71036501W
			Analogue output	isoHV425-D4M-4 with AGH422	B71036503
				isoHV425W-D4M-4 with AGH422W	B71036503W

Accessories

Description	Art. No.
Mounting clip for screw mounting (1 piece per device)	B98060008

Dimension diagram XM420

Dimensions in mm

Open the front plate cover in direction of arrow!

Screw mounting

Note: The upper mounting clip is an accessory and must be ordered separately (see accessories).

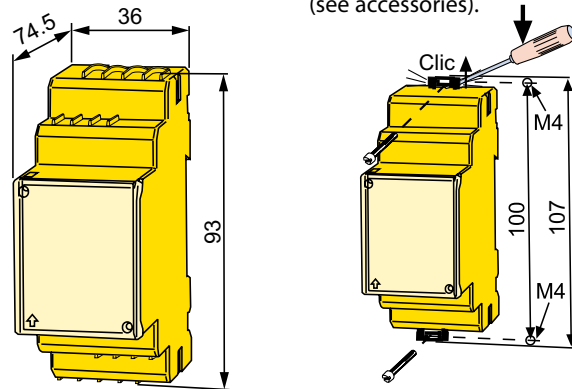

Operating elements

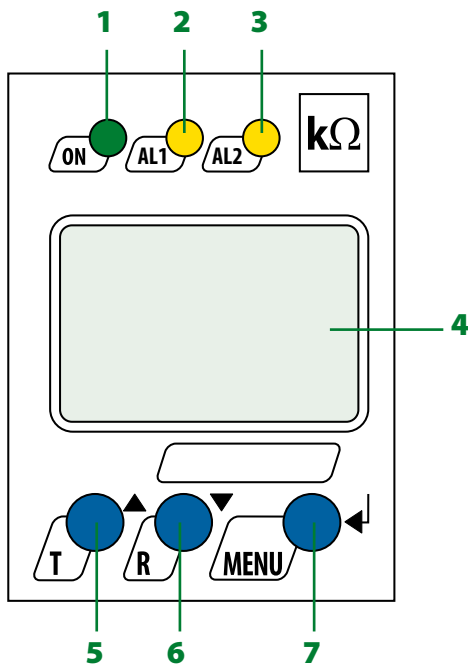

- 1 - Operation LED "ON" flashes in case of interruption of the connecting wires E/KE or L1(+)/L2(-) or system error.
- 2 - Alarm LED "AL1" lights when the values fall below the set response value of alarm 1 and flashes in case of interruption of the connecting wires E/KE or L1(+)/L2(-), in case of system errors as well as in case of overvoltage (can be activated).
- 3 - Alarm LED "AL2" lights when the values fall below the set response value of alarm 2 and flashes in case of interruption of the connecting wires E/KE or L1(+)/L2(-), in case of system errors as well as in case of undervoltage (can be activated).
- 4 - LC display
- 5 - Test button "T": Call up self test
Arrow-up button: Change parameters, move upwards in the menu
- 6 - Reset button "R": Delete stored alarms
Arrow-down button: Change parameters, move down in the menu
- 7 - Menu button "MENU": Call up the menu system
Enter button: Confirm parameter changes

Wiring diagram isoHV425-D4-4

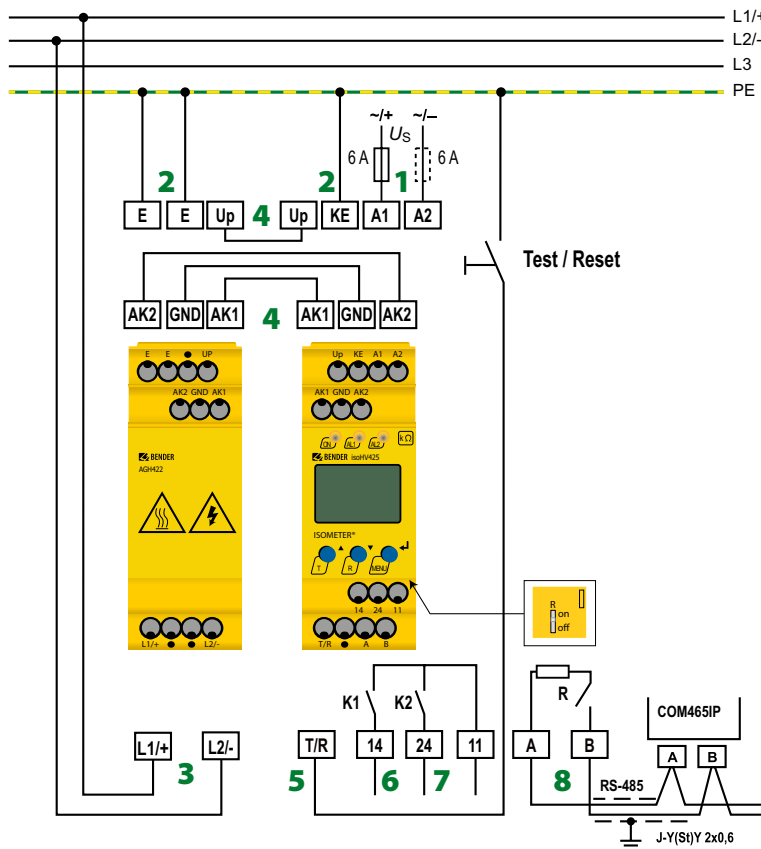

- 1 - A1, A2 Connection to the supply voltage via fuse (line protection). If being supplied from an IT system, both lines have to be protected by a fuse.
- 2 - E, KE Connect each terminal separately to PE:
The same wire cross section as for A1, A2 is to be used
- 3 - L1/+, L2/- Connection to the IT system to be monitored
- 4 - Up, AK1, GND, AK2 Connect the terminals of the AGH422 to the corresponding terminals of the ISOMETER®.
- 5 - T/R Connection for the external combined test/reset button
- 6 - 11, 14 Connection to alarm relay K1
- 7 - 11, 24 Connection to alarm relay K2
- 8 - A, B RS-485 communication interface with connectable terminating resistor.

Wiring diagram isoHV425-D4M-4

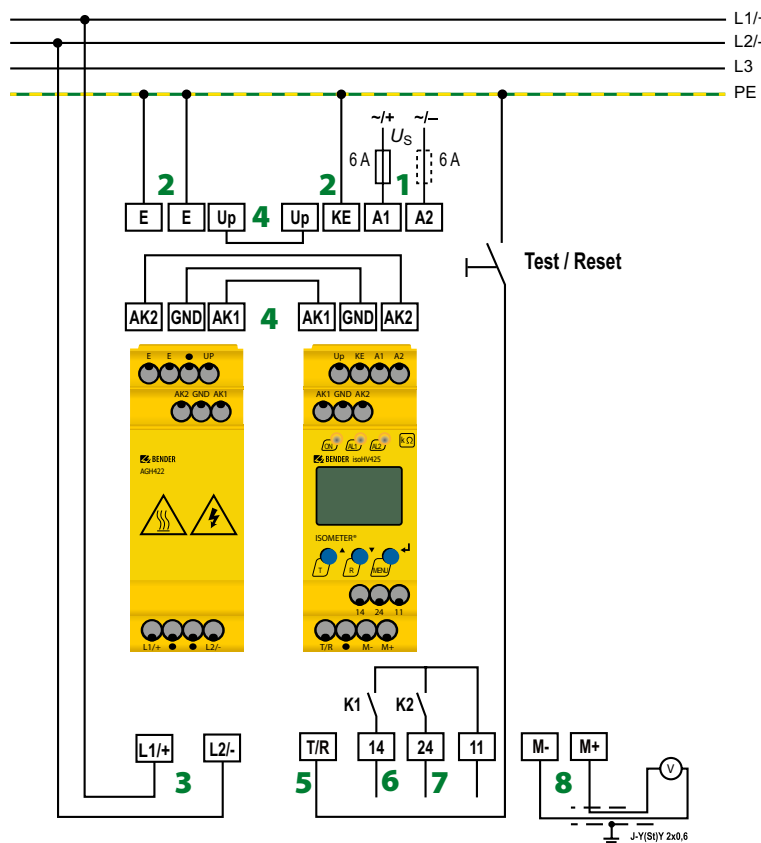

- 1 - A1, A2 Connection to the supply voltage via fuse (line protection). If being supplied from an IT system, both lines have to be protected by a fuse.
- 2 - E, KE Connect each terminal separately to PE:
The same wire cross section as for A1, A2 is to be used
- 3 - L1/+, L2/- Connection to the IT system to be monitored
- 4 - Up, AK1, GND, AK2 Connect the terminals of the AGH422 to the corresponding terminals of the ISOMETER®.
- 5 - T/R Connection for the external combined test/reset button
- 6 - 11, 14 Connection to alarm relay K1
- 7 - 11, 24 Connection to alarm relay K2
- 8 - M+, M- Analogue output

Technical data ISOMETER® isoHV425

Insulation coordination acc. to IEC 60664-1/IEC 60664-3

Definitions:	
Supply circuit (IC2)	A1, A2
Output circuit (IC3)	11, 14, 24
Control circuit (IC4)	Up, KE, T/R, A, B, AK1, GND, AK2, M+, M-
Rated voltage	240 V
Overvoltage category	III
Rated impulse voltage:	
IC2/(IC3-4)	4 kV
IC 3/IC4	4 kV
Rated insulation voltage:	
IC2/(IC3-4)	250 V
IC 3/IC4	250 V
Pollution degree	3
Protective separation (reinforced insulation) between:	
IC2/(IC3-4)	overvoltage category III, 300 V
IC 3/IC4	overvoltage category III, 300 V
Voltage tests (routine test) acc. to IEC 61010-1:	
IC2/(IC3-4)	AC 2.2 kV
IC 3/IC4	AC 2.2 kV

Supply voltage

Supply voltage U_S	AC 100...240 V/DC 24...240 V
Tolerance of U_S	-30...+15 %
Frequency range U_S	47...63 Hz
Power consumption	≤ 3 W, ≤ 9 VA

IT system being monitored

Nominal system voltage U_n with AGH422	AC 0...1000 V/DC 0...1000 V
Tolerance of U_n	AC +10 %, DC +10 %
Frequency range of U_n	DC, 15...460 Hz

Measuring circuit

Permissible system leakage capacitance C_e	≤ 150 μ F
Permissible extraneous DC voltage U_{fg}	≤ 1600 V

Response values

Response value R_{an1}	11...500 k Ω (50 k Ω)*
Response value R_{an2}	10...490 k Ω (25 k Ω)*
Relative uncertainty R_{an}	± 15 %, at least ± 3 k Ω
Hysteresis R_{an}	25 %, at least 1 k Ω
Undervoltage detection	30...1.09 kV (off)*
Overvoltage detection	31...1.10 kV (off)*
Relative uncertainty U	± 5 %, at least ± 5 V
Relative uncertainty depending on the frequency ≥ 200 Hz	-0.075 %/Hz
Hysteresis U	5 %, at least 5 V

Time response

Response time t_{an} at $R_F = 0.5 \times R_{an}$ and $C_e = 1$ μ F acc. to IEC 61557-8	≤ 20 s
Start-up delay t	0...10 s (0 s)*
Response delay t_{on}	0...99 s (0 s)*
Delay on release t_{off}	0...99 s (0 s)*

Displays, memory

Display	LC display, multi-functional, not illuminated
Display range measured value insulation resistance (R_F)	1 k Ω ...4 M Ω
Operating uncertainty	± 15 %, at least ± 3 k Ω
Display range measured value nominal system voltage (U_n)	30...1.15 kV _{RMS}
Operating uncertainty	± 5 %, at least ± 5 V
Display range measured value system leakage capacitance for $R_F > 20$ k Ω	0...200 μ F
Operating uncertainty	± 15 %, at least ± 2 μ F
Password	off/0...999 (0, off)*
Fault memory alarm messages	on/(off)*

Interface (valid for isoHV425-D4-4 only)

Interface/protocol	RS-485/BMS, Modbus RTU, isoData (BMS)*
Baud rate	BMS (9.6 kbit/s), Modbus RTU (selectable), isoData (115.2 kbit/s)
Cable length (9.6 kbit/s)	≤ 1200 m
Cable: twisted pairs, shield connected to PE on one side	min. J-Y(St)Y 2x0.6
Terminating resistor	120 Ω (0.25 W), internal, can be connected
Device address, BMS bus, Modbus RTU	3...90 (3)*

Analogue output (valid for isoHV425-D4M-4 only)

Operating mode	mid-scale R or full-scale U ($R = 120$ k Ω)*
Functions	insulation value R_F or mains voltage U_n (R_F)*
Max. no load voltage (open terminals)	DC 12 V
Max. short-circuit current	25 mA short-circuit proof
Voltage output	DC 0...10 V, load ≥ 20 k Ω *
Current output	DC 0/4...20 mA, load ≤ 130 Ω
Current output	DC 0...400 μ A, load ≤ 3 k Ω

Switching elements

Switching elements	2 x 1 N/O contact, common terminal 11
Operating principle	N/C operation/N/O operation (N/C operation)*
Electrical endurance under rated operating conditions, number of cycles	10,000

Contact data acc. to IEC 60947-5-1:

Utilisation category	AC-12	AC-14	DC-12	DC-12	DC-12
Rated operational voltage	230 V	230 V	24 V	110 V	220 V
Rated operational current	5 A	2 A	1 A	0.2 A	0.1 A
Minimum contact rating	1 mA at AC/DC ≥ 10 V				

Environment/EMC

EMC	IEC 61326-2-4, EN 50121-3-2
-----	-----------------------------

Ambient temperatures:

Operation	-40...+70 $^{\circ}$ C
Transport	-40...+85 $^{\circ}$ C
Storage	-40...+70 $^{\circ}$ C

Classification of climatic conditions acc. to IEC 60721:

Stationary use (IEC 60721-3-3)	3K23 (except condensation and formation of ice)
for W variant	3K24
Transport (IEC 60721-3-2)	2K11 (except condensation and formation of ice)
Long-term storage (IEC 60721-3-1)	1K22 (except condensation and formation of ice)

Classification of mechanical conditions acc. to IEC 60721:

Stationary use (IEC 60721-3-3)	3M11
for W variant	3M12
Transport (IEC 60721-3-2)	2M4
Long-term storage (IEC 60721-3-1)	1M12

Connection		Other	
Connection type	push-wire terminal	Operating mode	continuous operation
Nominal current	≤ 10 A	Mounting	cooling slots must be ventilated vertically
Conductor sizes	AWG 24-14	Minimum horizontal distance between the devices (DIN EN 45545)	see note **
Stripping length	10 mm	Degree of protection, built-in components (DIN EN 60529)	IP30
Rigid	0.2...2.5 mm ²	Degree of protection, terminals (DIN EN 60529)	IP20
Flexible without ferrules	0.75...2.5 mm ²	Enclosure material	polycarbonate
Flexible with ferrule with/without plastic sleeve	0.25...2.5 mm ²	DIN rail mounting acc. to	IEC 60715
Multiple conductor, flexible with TWIN ferrule with plastic sleeve	0.5...1.5 mm ²	Screw mounting	2 x M4 with mounting clip
Opening force	50 N	Weight	≤ 150 g
Test opening, diameter	2.1 mm		

(*) = Factory setting

Technical data coupling device AGH422

Insulation coordination acc. to IEC 60664-1/IEC 60664-3

Definitions:

Measuring circuit (IC1)	L1+, L2/-
Control circuit (IC2)	AK1, GND, AK2, Up, E
Rated voltage	1000 V
Overvoltage category	III
Rated impulse voltage:	
IC1/IC2	8 kV
Rated insulation voltage:	
IC1/IC2	1000 V
Pollution degree	3
Protective separation (reinforced insulation) between:	
IC1/IC2	Overvoltage category III, 1000 V

IT system being monitored

Nominal system voltage range U_n	AC 0...1000 V/DC 0...1000 V
Tolerance of U_n	AC +10%/DC +10%

Measuring circuit

Measuring voltage U_m	±45 V
Measuring current I_m for R_f	≤ 120 µA
Internal resistance R_i	≥ 390 kΩ

Environment/EMC

EMC	IEC 61326-2-4, EN 50121-3-2
-----	-----------------------------

Ambient temperatures:

Operation	
$U_n < 700$	-40...+70 °C
$U_n > 700$	-40...+55 °C
Transport	-40...+85 °C
Storage	-40...+70 °C

Classification of climatic conditions acc. to IEC 60721:

Stationary use (IEC 60721-3-3)	3K23 (except condensation and formation of ice)
for W variant	3K24
Transport (IEC 60721-3-2)	2K11 (except condensation and formation of ice)
Long-term storage (IEC 60721-3-1)	1K22 (except condensation and formation of ice)

Classification of mechanical conditions acc. to IEC 60721:

Stationary use (IEC 60721-3-3)	3M11
for W variant	3M12
Transport (IEC 60721-3-2)	2M4
Long-term storage (IEC 60721-3-1)	1M12

Connection

Connection type	push-wire terminal
Push-wire terminals:	
Nominal current	10 A
Conductor sizes	AWG 24 -14
Stripping length	10 mm
Rigid	0.2...2.5 mm ²
Flexible without ferrules	0.75...2.5 mm ²
Flexible with ferrule with/without plastic sleeve	0.25...2.5 mm ²
Multiple conductor, flexible with TWIN ferrule with plastic sleeve	0.5...1.5 mm ²
Opening force	50 N
Test opening, diameter	2.1 mm

Single cables for terminals Up, AK1, GND, AK2 – Requirement for connecting cables between isoHV425xx and AGH422

Cable length	≤ 0.5 m
Wire cross-section	≥ 0.75 mm ²

Other

Operating mode	continuous operation
Mounting	cooling slots must be ventilated vertically
Distance to adjacent devices from $U_n > 800$ V	≥ 30 mm
Minimum horizontal distance between the devices (DIN EN 45545)	see note *
Degree of protection, built-in components (DIN EN 60529)	IP30
Degree of protection, terminals (DIN EN 60529)	IP20
Enclosure material	polycarbonate
DIN rail mounting acc. to	IEC 60715
Screw mounting	2 x M4 with mounting clip
Weight	150 g

** Application in rail vehicles / DIN EN 45545-2:2016!
 If the distance to neighbouring components that do not meet the requirements of the DIN EN 45545-2 Table 2 standard is < 20 mm horizontally or < 200 mm vertically, these are to be regarded as grouped. See DIN EN 45545-2 Chapter 4.3 Grouping rules.



Bender GmbH & Co. KG

PO Box 1161 • 35301 Grünberg • Germany

Londorfer Straße 65 • 35305 Grünberg • Germany

Tel.: +49 6401 807-0 • Fax: +49 6401 807-259

E-mail: info@bender.de • www.bender.de



BENDER Group